

MH8220 INSTRUCTION MANUAL

PARTS LIST

QTY	REFERENCE	DESCRIPTION
1	A	Support Frame (L)
1	B	Support Frame (R)
2	C	Frame Connector
1	D	Top Frame Connector
1	E	Bottom Frame Connector
5	F	Zinc Plated Reel Shaft
1	G	Zinc Plated Wheel Axle
2	H	Wheel

HARDWARE KIT

QTY	REFERENCE	DESCRIPTION
4	J	1/4-20 x 1-1/2 Carriage Bolt
4	K	1/4 x 1/2 Flat Washer
4	L	1/4-20 Nylon-insert Lock Nut
2	M	5/8 x 1-3/4 Flat Washer
10	N	3 x 65 Hitch Pin Clip
2	O	1-1/2 Cotter Pin
2	P	5/8 x 1-1/8 Flat Washer

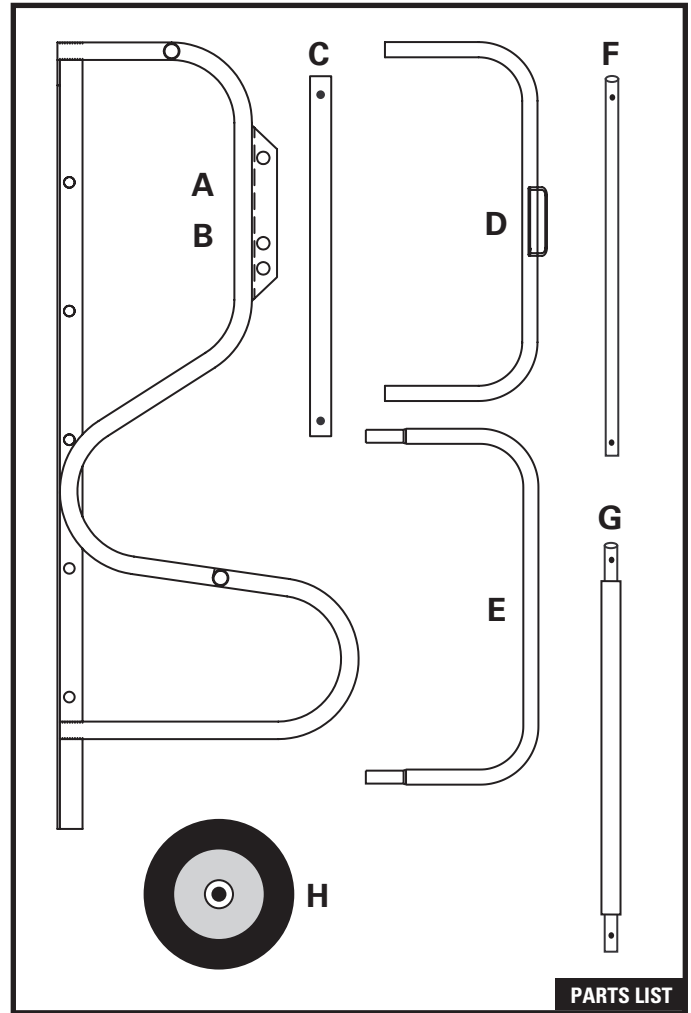
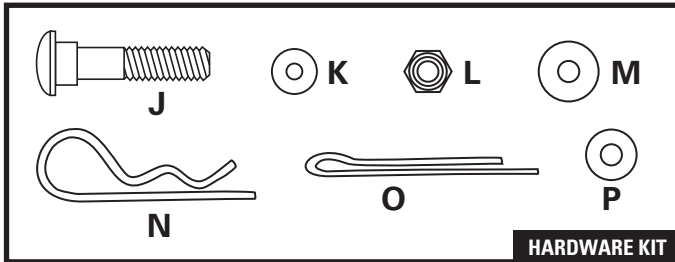

SAFETY RULES

This product was designed for certain applications only. Madison strongly recommends that this product not be modified and/or used for any purpose other than that for which it was designed.

CAUTION: Use care when lifting the Multi-purpose Cart. Unload spools first. Do not use as a step or ladder.

Tools Required for Assembly

7/16-inch wrench or socket. Channel lock or vise grip pliers.

For Parts, Accessories or Warranty Assistance, Please call: **1-800-631-7775**

CAPACITY	# OF SPOOLS	SPOOL DIMENSIONS
	6	2500' - up to 16" diameter
	15	500' - 7" diameter x 5" wide



WireSMART

MULTI-PURPOSE CART

ASSEMBLY INSTRUCTIONS

FIGURE 1

With Support Frame (A) on flat surface, push down firmly on Frame Connector (C) until ball pin in Support Frame (A) snaps into hole in Frame Connector (C). Repeat for the second Frame Connector.

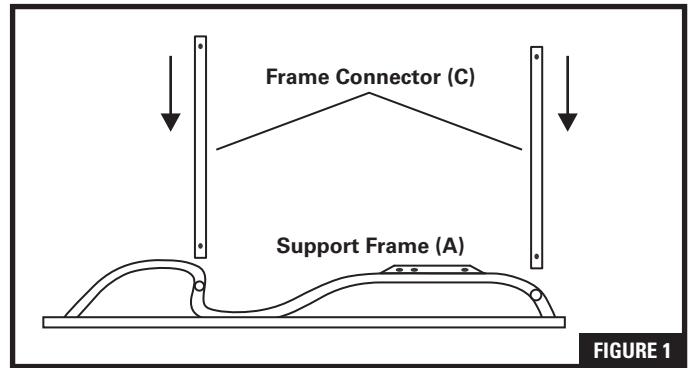

FIGURE 1

FIGURE 2

Slide one Small Washer (P) onto the Wheel Axle (G), followed by one Wheel (H), and one Large Washer (M). Insert the wheel/axle assembly into the bottom hole of the Support Frame (A) and secure using one Cotter Pin (O), bending both sides of Cotter Pin upward to lock into place. Install the second Small Washer (P) onto the other end of the Wheel Axle (G), followed by the remaining Wheel (H), and Large Washer (M).

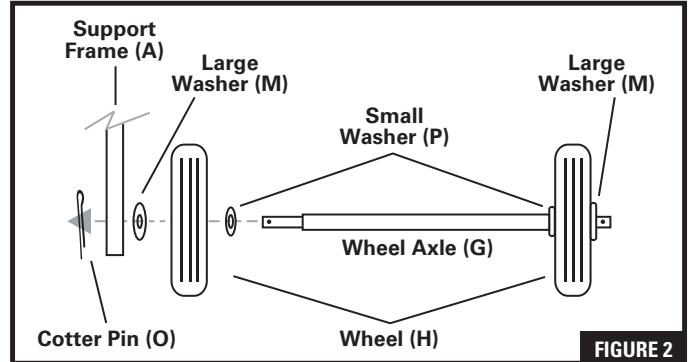

FIGURE 2

FIGURE 3

Line up Support Frame (B) over the Frame Connectors (C) and Wheel Axle (G). Insert the wheel/axle assembly into the bottom hole of the Support Frame (B). Push down until ball pins in Support Frame (B) snap into the holes in the Frame Connectors (C). Insert the other Cotter Pin (O) into the end of the Wheel Axle (G), bending both sides of Cotter Pin upward to lock into place.

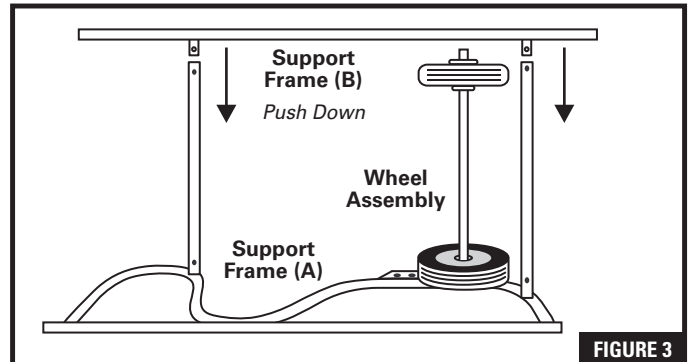

FIGURE 3

FIGURE 4

With Wire Guide facing down, position the Top Frame Connector (D) in between the Support Frames (A and B). Secure using the 1/4-20 x 1-1/2" Carriage Bolt (J), 1/4" x 1/2" Flat Washer (K), and 1/4-20 Nylon-Insert Locknut (L).

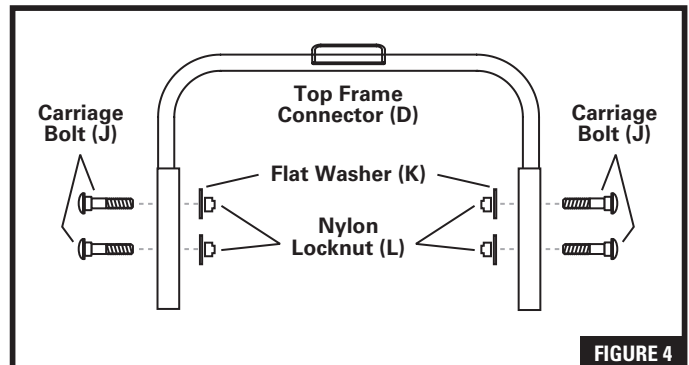

FIGURE 4

FIGURE 5

With the unit in a horizontal position, insert the Bottom Frame Connector (E) into the holes in the Support Frames (A and B). Push down equally on both sides until ball pins in the Bottom Frame Connector (E) snap into the holes in the Support Frames (A and B).

FIGURE 6

Insert the Zinc Plated Reel Shafts (F) through the holes in the front of Support Frames (A and B), secure using 3 x 65 Hitch Pin Clips (N).

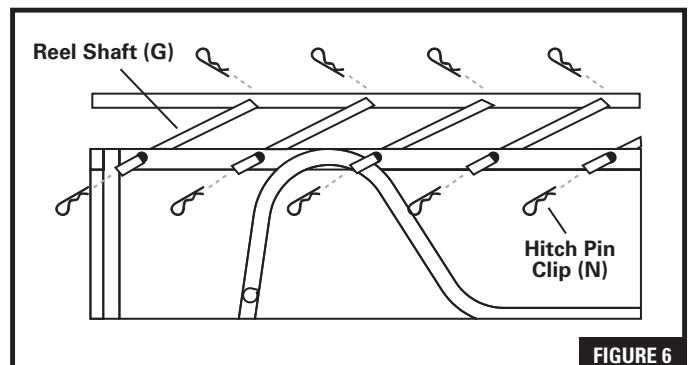

FIGURE 6

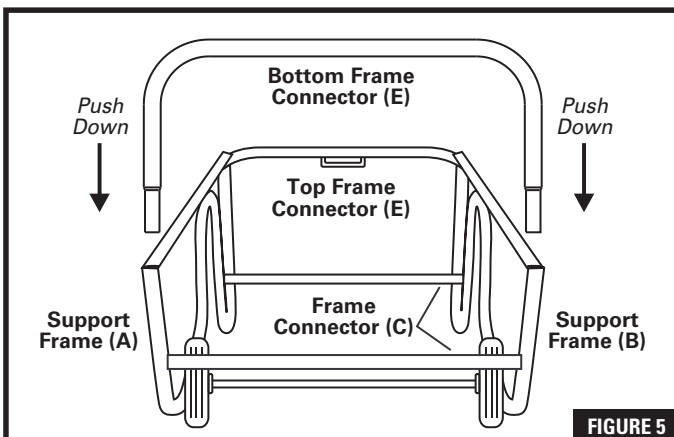

FIGURE 5